



**AIR OPERATED
DOUBLE
DIAPHRAGM
PUMPS**



ISO 9001: 2008
ISO 14001: 2004

pricepumps.co.in

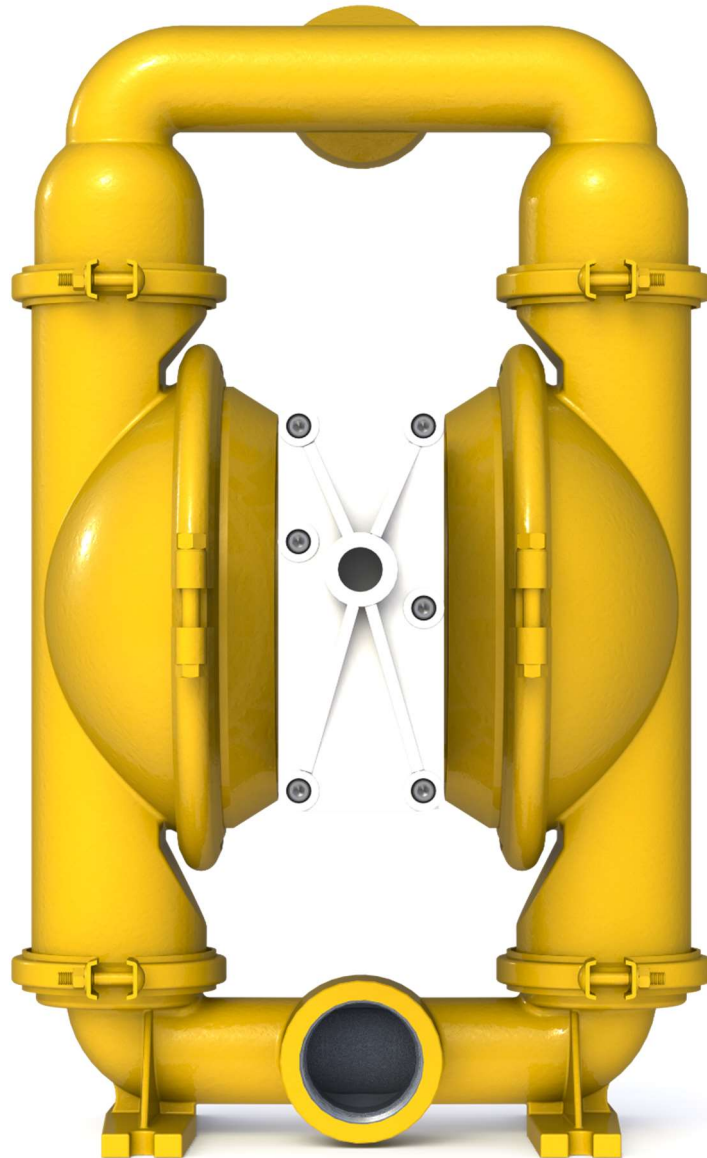

**3" ALUMINIUM PUMP
AOD 80 PFF AAPP/TEF/TF/A/T**

pricepumps.co.in



AIR OPERATED DOUBLE DIAPHRAGM PUMPS



ISO 9001: 2008
ISO 14001: 2004

pricepumps.co.in

SECTION 1- LEGEND

3" ALUMINIUM PUMP

AOD 80/AAPP/TEF/TF/A/T

MODEL: AOD 80 PFF ALUMINIUM

76mm (3") Pump

Maximum Flow Rate: 900 Lpm (238 gpm)

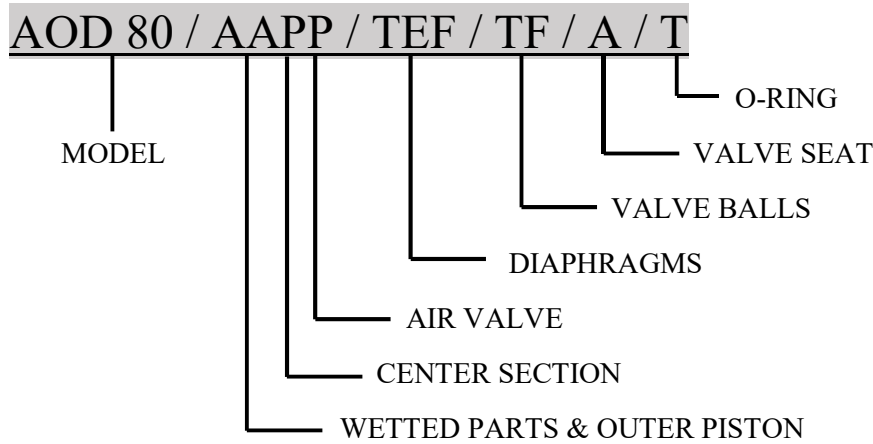

MATERIAL CODES

MODEL
AOD 80 = 3" PUMP

AIR VALVE
P = POLYPROPYLENE

VALVE BALL
TF = TEFLON

WETTED PARTS & OUTER PISTON
AA = ALUMINIUM /
ALUMINIUM

DIAPHRAGMS
TEF = TEFLON

VALVE SEAT
A = ALUMINIUM

CENTER SECTION
P = POLYPROPYLENE

VALVE SEAT O-RING
T = TEFLON



AIR OPERATED DOUBLE DIAPHRAGM PUMPS



ISO 9001: 2008
ISO 14001: 2004

pricepumps.co.in

SECTION 2 – SPARE PART LIST

3” ALUMINIUM PUMP

AOD 80/AAPP/TEF/TF/A/T

SR No.	DISCRIPTION	PART No	QTY
1	LIQUID CHAMBER	80-1001-01	2
2	SUCTION MANIFOLD	80-1021-01	1
3	DISCHARGE MANIFOLD	80-1031-01	1
4	NRV BALL	80-1041-55	4
5	BALL SEAT	80-1072-01	4
6	SEAT O RING	80-3101-55	4
7	HOLDING PLATE	80-1111-02	2
8	LOCK NUT	80-1131-01	2
9	DIAPHRAGM	80-2002-55	2
10	BACKUP DIAPHRAGM	80-2101-58	2
11	CHAMBER CLAMP	80-1231-61	4
12	SUCTION DISCHARGE CLAMP	80-1222-61	8
13	CENTER BLOCK	80-1301-20	1
14	CENTER BLOCK O RING	80-3155-56	2
15	CENTER BLOCK PIPE	80-1320-03	4
16	CENTER BLOCK PATTI	80-1319-03	6
17	MAIN SHAFT SS	80-1341-03	1
18	AIR COVER	80-1405-01	2
19	AIR COVER GASKET	80-3311-51	2
20	PILOT BUSH	80-1471-07	1
21	PILOT SHAFT	80-1454-03	1
22	PILOT SHAFT O RING	80-3176-51	8
23	PILOT SHAFT O RING	80-3171-68	4
24	PILOT LOCK O RING	40-3166-51	2
25	PILOT SHAFT WASHER	04-6114-03	2
26	PILOT BUSH O RING	30-3151-51	4



AIR OPERATED DOUBLE DIAPHRAGM PUMPS



ISO 9001: 2008
ISO 14001: 2004

pricepumps.co.in

SECTION 2 – SPARE PART LIST (CONTINUED...)

3” ALUMINIUM PUMP

AOD 80/AAPP/TEF/TF/A/T

SR No.	DISCRIPTION	PART No	QTY
27	PISTON BLOCK	80-1501-20	1
28	PISTON	80-1521-69	1
29	PISTON O RING BIG	80-3201-51	1
30	PISTON O RING SMALL	80-3224-51	7
31	PISTON RING BIG	80-3241-68	1
32	PISTON RING SMALL	80-3246-68	3
33	PISTON RING MEDIUM	80-3251-68	2
34	PISTON BLOCK CAP	80-1571-20	1
35	PISTON BLOCK CAP O RING	80-3266-51	1
36	PISTON BLOCK COVER	80-1561-20	1
37	PISTON BLOCK GASKET	80-3321-51	1
38	PISTON BLOCK COVER GASKET	80-3331-51	1
39	PISTON BLOCK PIPE	80-1586-03	2
40	EXHAUST	80-1366-23	1
41	AIR NIPPLE	50-1371-07	1
42	REDUCER	80-1377-21	1
43	½" X ¾" HEX BOLTS SS (CHAMBER BOLTS)	04-6007-03	4
44	½ SS HEX NUT UNC	04-6301-03	4
45	3/8 X 20.7 X 1.5 MM SS WASHER (SUC/DIS CLAMP)	04-6210-03	8
46	3/8" X 60 MM CARRIAGE BOLTS SS (SUC/DIS)	04-6022-03	8
47	3/8 SS HEX NUT	04-6304-03	8
48	3/8" X 1¼" HEX BOLTS SS (AIR COVER/ H P)	04-6016-03	24
49	3/8 X 3 MM SS WASHER (AIR COVER)	04-6206-03	12
50	3/8" X 6" ALLEN BOLTS MS (PISTON BLOCK)	04-6021-61	6
51	3/8" X 11.4 X 3 MM SS WASHER (P B ALLEN BOLT)	04-6207-03	6
52	35 X 20 X 3 MM SS WASHER (HOLDING PLATE)	04-6217-61	2
53	3/8 X 25 X 3 MM SS WASHER HP (AOD 300 PP SUC/DIS BOLT WASHER)	04-6212-61	12



AIR OPERATED DOUBLE DIAPHRAGM PUMPS



ISO 9001: 2008
ISO 14001: 2004

pricepumps.co.in

SECTION 3 – EXPLODED VIEW

3" ALUMINIUM PUMP

AOD 80/AAPP/TEF/TF/A/T

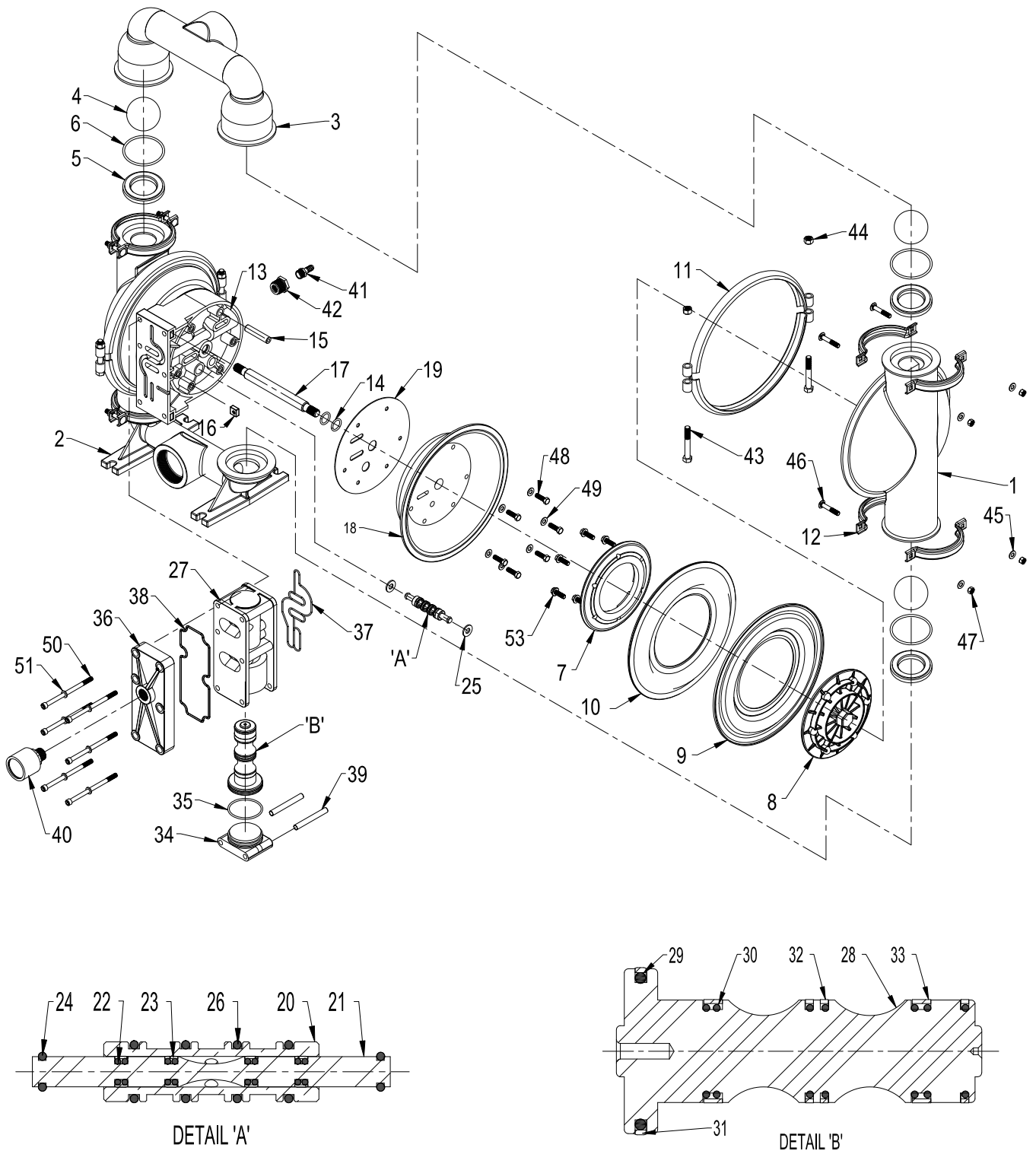



AIR OPERATED DOUBLE DIAPHRAGM PUMPS



ISO 9001: 2008
ISO 14001: 2004

pricepumps.co.in

SECTION 4 – DIMENSIONAL DRAWING

3" ALUMINIUM PUMP

AOD 80/AAPP/TEF/TF/A/T

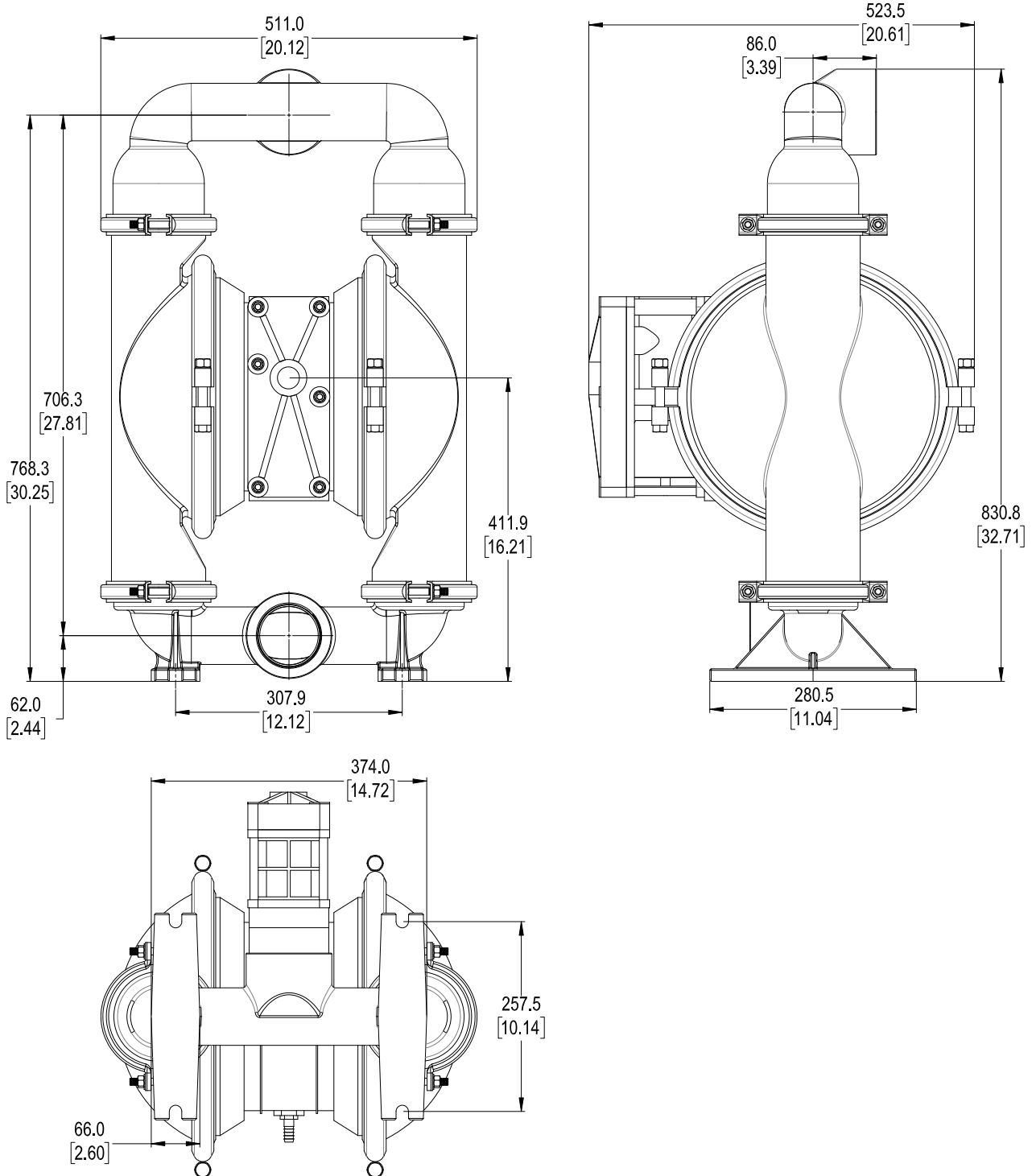



AIR OPERATED DOUBLE DIAPHRAGM PUMPS



ISO 9001: 2008
ISO 14001: 2004

pricepumps.co.in

SECTION 5 – SPECIFICATION & PERFORMANCE

3” ALUMINIUM PUMP

AOD 80/AAPP/TEF/TF/A/T

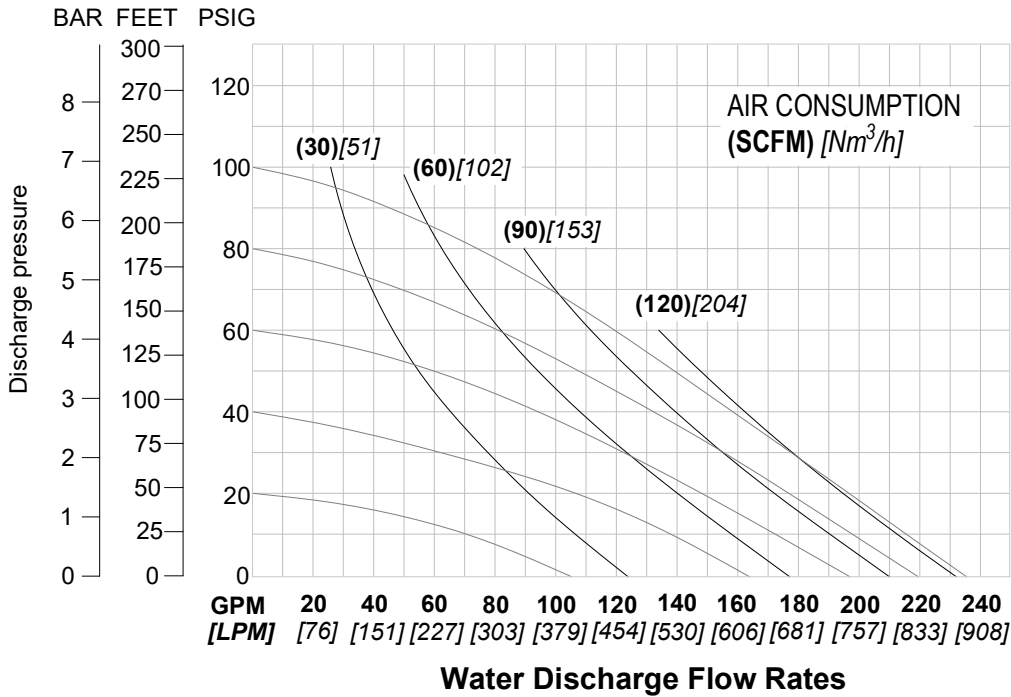

SPECIFICATIONS:

MAX FLOW RATE:	900 Lpm (238 gpm)
MAX AIR PRESSURE:	100 psi (6.9 bar)
AIR INLET:	13 mm (1/2" BSP)
PORT INLET:	76 mm (3" BSP)
DISCHARGE:	76 mm (3" BSP)
SUCTION LIFT : DRY :	6.6 m (21.6')
WET :	8.6 m (28.4')
MAX PARTICLE SIZE:	(Dia) 9.5 mm (3/8")
AIR EXHAUST:	25.4 mm (1" BSP)

SHIPPING DIMENSIONS:

HEIGHT:	1050 mm (41.34")
WIDTH:	690 mm (27.16")
LENGTH:	550 mm (21.65")
WEIGHT:	61 Kgs

Price Pumps meet ISO 9001-2015, ISO 14001 & CE quality standards.



**AIR OPERATED
DOUBLE
DIAPHRAGM
PUMPS**



ISO 9001: 2008
ISO 14001: 2004

pricepumps.co.in

NOTES: